









# Fashion Bed Group

A Division of Leggett & Platt Incorporated

## Parts List For Chatham

BED CARTON	HEADBOARD CARTON				
(9) HEADBOARD PANEL (10) FOOTBOARD PANEL	(9) HEADBOARD PANEL				
PART #327301 HARDWARE BAG FOR BED ATTACHMENT TO FRAME	PART #327302 HARDWARE BAG FOR HEADBOARD ATTACHMENT TO FRAME				
(1) 1/4-20 1" FLAT ALLEN HEAD SCREW-8 (2) 5/8" OD FLAT WASHER-8 (3) 7/8" OD RUBBER WASHER-8 (4) 1/4" ID LOCK WASHER-8 (5) ALLEN WRENCH (6) LEG EXTENSION (#327305-SATIN)-2 (7) FOOT RING (#327303-SATIN)-4 (8) PLASTIC GLIDE-4 (#150940000)	(1) 1/4-20 1" FLAT ALLEN HEAD SCREW-4 (2) 5/8" OD FLAT WASHER-4 (3) 7/8" OD RUBBER WASHER-4 (4) 1/4" ID LOCK WASHER-4 (5) ALLEN WRENCH (6) LEG EXTENSION (#327305-SATIN)-2 (7) FOOT RING (#327303-SATIN)-2 (8) PLASTIC GLIDE-2 (#150940000)				

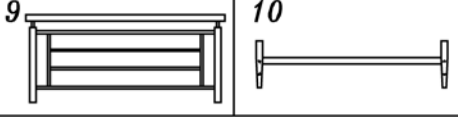
## PRODUCT FULLY ASSEMBLED

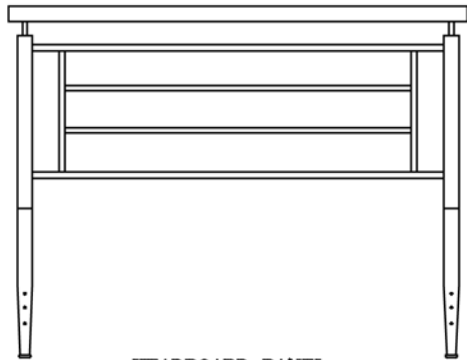

HEADBOARD PANEL

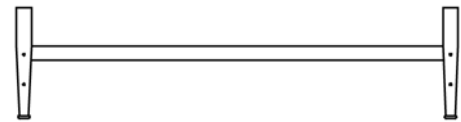

FOOTBOARD PANEL

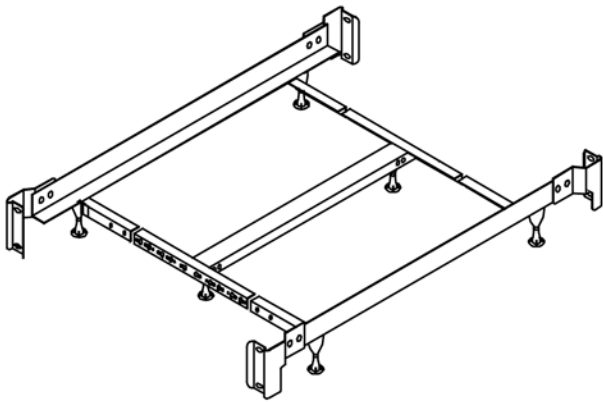

QUEEN - KING FRAME FULLY ASSEMBLED

NOTE: SEE INSTRUCTIONS INCLUDED IN FRAME CARTON FOR FRAME ASSEMBLY

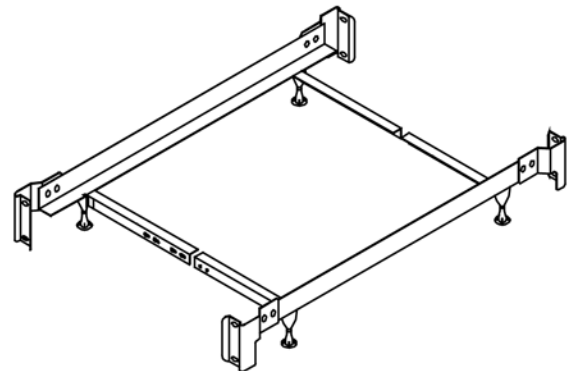

TWIN - FULL FRAME FULLY ASSEMBLED

NOTE: SEE INSTRUCTIONS INCLUDED IN FRAME CARTON FOR FRAME ASSEMBLY



# Instruction Sheet

SAVE ALL PACKAGING MATERIALS UNTIL PRODUCT IS FULLY ASSEMBLED. HARDWARE AND SMALL PIECES MAY NOT BE SEEN AND BE ACCIDENTALLY DISCARDED WITH PACKAGING MATERIALS.

FIGURE 1

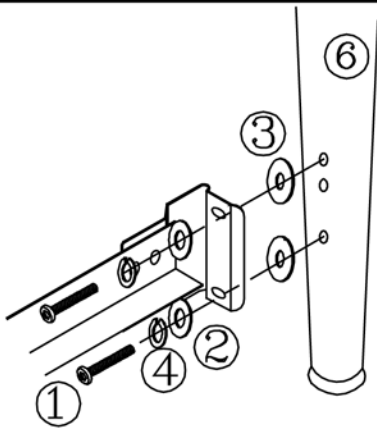
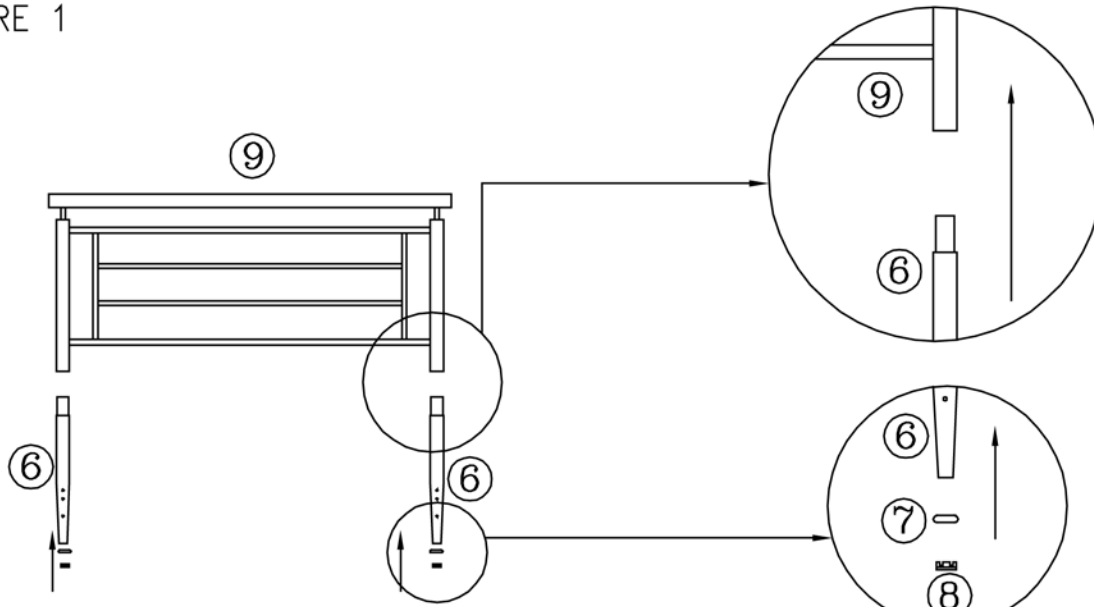

FIGURE 2

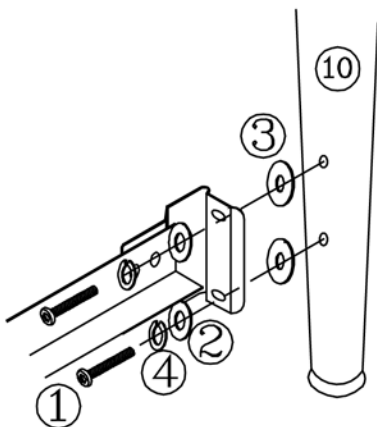

FIGURE 3

## Step 1

- Insert plastic glide (8) with foot ring (7) into bottom of leg extensions (6) and footboard (10) posts. (See Figure 1)
- Align top reduction of extension legs (6) with bottom of headboard posts. (See Figure 1) Make sure the 3 holes on extension legs are perpendicular to headboard panel.
- Now carefully insert extension legs (6) into bottom of headboard (9) posts.

## Step 2

- Place headboard and frame in desired location in room.
- Place lock washer (4) and flat washer (2) on each screw (1). Insert through bracket, rubber washer (3) and into leg extension (6). Hand-tighten, DO NOT TIGHTEN screws all the way.
- Repeat on other side of headboard.
- Tighten all screws securely using the Allen wrench.

## Step 3

- Position footboard (10) panel and align holes in the post with holes in the frame bracket. (See figure 3)
- Place lock washer (4) and flat washer (2) on each screw (1). Insert through bracket, rubber washer (3) and into post. Hand-tighten, DO NOT TIGHTEN screws all the way.
- Repeat on other side of footboard panel.
- Tighten all screws securely using the Allen wrench.