

# Fashion Bed Group

A Division of Leggett & Platt Incorporated















## Parts List For Dynasty Bed

### BED CARTON

- (13) HEADBOARD PANEL
- (14) FOOTBOARD PANEL

PART #305201 HARDWARE BAG FOR BED ATTACHMENT TO FRAME

- (1) 1/4-20 2 1/4" COUNTER SUNK ALLEN HEAD SCREW-4
- (2) 1/4-20 1" FLAT ALLEN HEAD SCREW-4
- (3) 1/4-20 1/2" FLAT ALLEN HEAD SCREW-4
- (4) 1/4-20 HEX NUT-4
- (5) 5/8" OD FLAT WASHER-8
- (6) 1/4" ID LOCK WASHER-8
- (7) 7/8" OD RUBBER WASHER-8
- (8) ALLEN WRENCH
- (9) OPEN WRENCH
- (10) PLASTIC GLIDE-4
- (11) FINIAL-4
- (12) LEG EXTENSION-2

1 	2 	3 	4 
5 	6 	7 	8 
9 	10 	11 	
12 	13 		
14 			

### PRODUCT FULLY ASSEMBLED

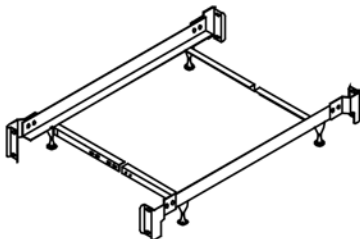
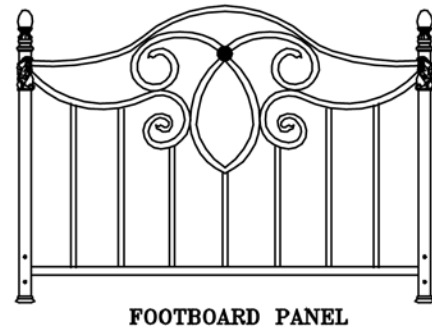
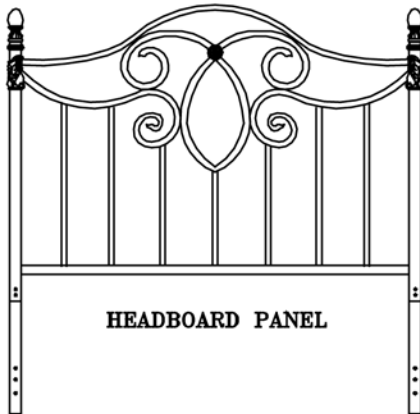

TWIN - FULL BED FRAME FULLY ASSEMBLED  
NOTE: SEE INSTRUCTIONS INCLUDED IN FRAME CARTON FOR FRAME ASSEMBLY

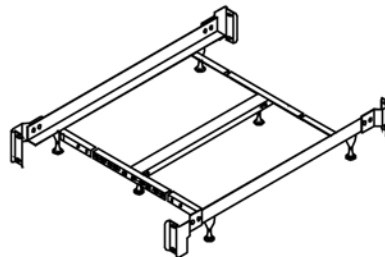

QUEEN - KING BED FRAME FULLY ASSEMBLED  
NOTE: SEE INSTRUCTIONS INCLUDED IN FRAME CARTON FOR FRAME ASSEMBLY



# Instruction Sheet

SAVE ALL PACKAGING MATERIALS UNTIL PRODUCT IS FULLY ASSEMBLED. HARDWARE AND SMALL PIECES MAY NOT BE SEEN AND BE ACCIDENTALLY DISCARDED WITH PACKAGING MATERIALS.

FIGURE 1

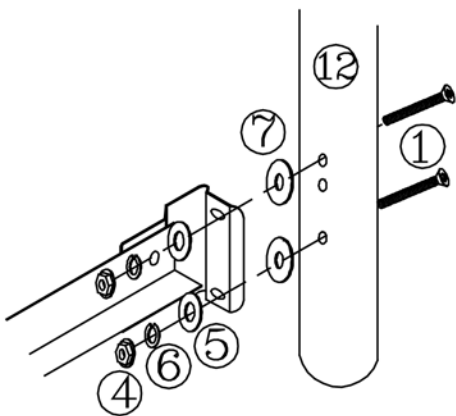
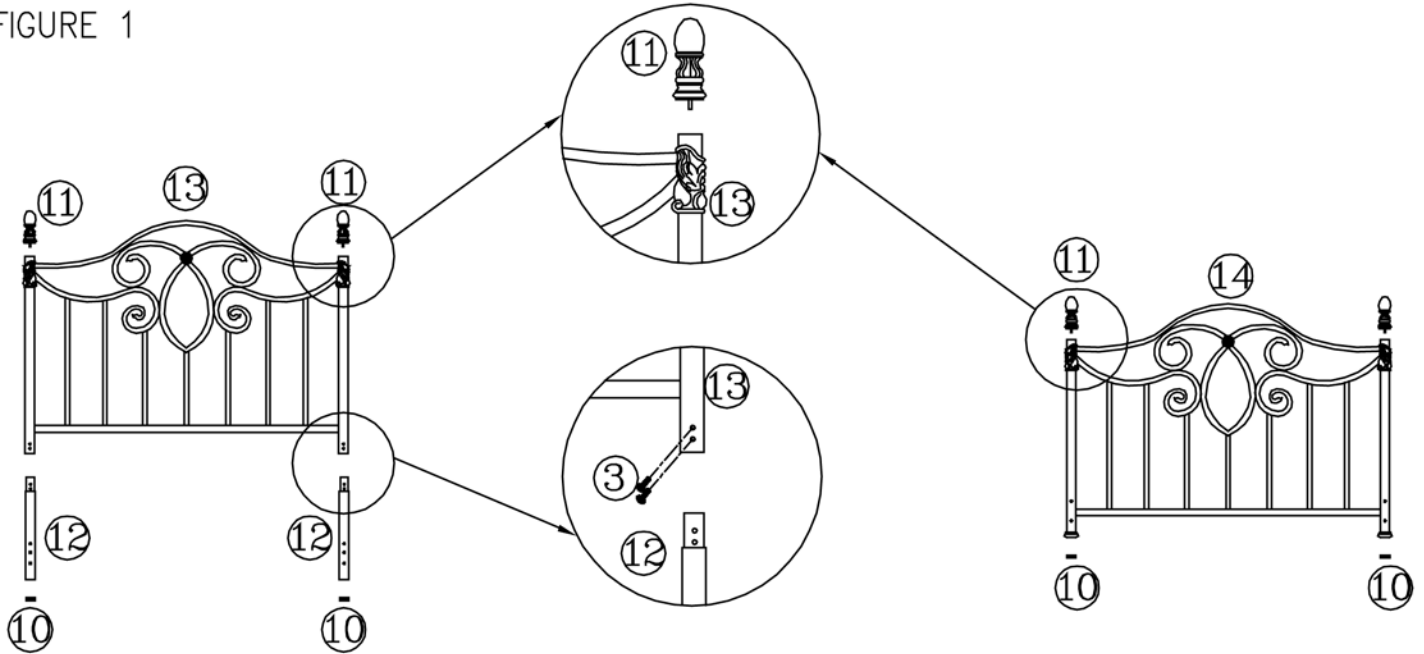

FIGURE 2

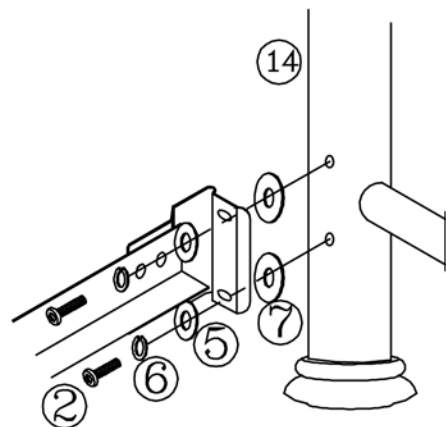

FIGURE 3

## Step 1

- Insert plastic glide (10) into bottom of leg extensions (12).
- Align top reduction of extension legs (12) with bottom of headboard posts. (See Figure 1) Make sure the 3 holes on extension legs are perpendicular to headboard panel.
- Now carefully insert extension legs (12) into bottom of headboard (13) posts. Secure legs to headboard posts with screws (3). (See Figure 1)
- Screw in finials (11) into headboard and footboard posts.
- Insert plastic glide (10) into bottom of footboard (14) posts.

## Step 2

- Place headboard and frame in desired location in room.
- Place 2 screws (1) through holes located in leg (12). (See Figure 2) Slide rubber washers (7) over screws (1).
- Align bed frame bracket over screws.
- Place a flat washer (5), a lock washer (6) and then a nut (4) on each screw. Hand-tighten, DO NOT TIGHTEN screws all the way.
- Repeat on other side of headboard.
- Tighten all screws securely using the Allen wrench (8) and open wrench (9).

## Step 3

- Position footboard panel (14) and align holes in the post with holes in the frame bracket. (See figure 3)
- Place a lock washer (6) and a flat washer (5) on each screw (2). Insert through bracket, rubber washer (7) and into post. Hand-tighten, DO NOT TIGHTEN screws all the way.
- Repeat on other side of footboard panel.
- Tighten all screws securely using the Allen wrench (8).